

MEDUSA

USER INSTRUCTIONS

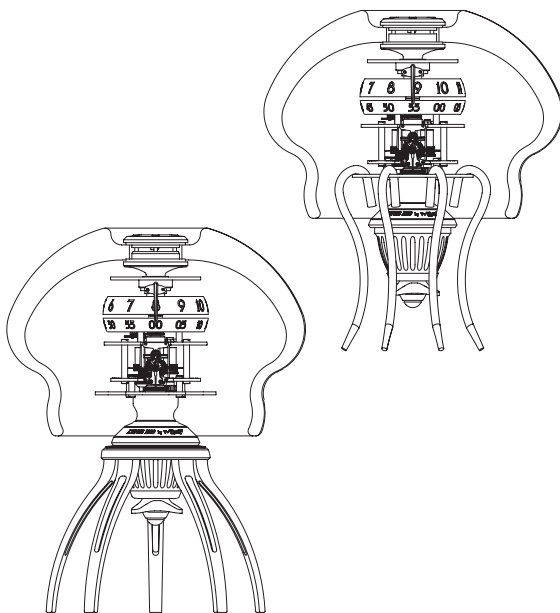

MB&F + *L'ÉPÉE* 1839

CONGRATULATIONS

You have just adopted Medusa,
an advanced timepiece born
from the partnership between
La Manufacture L'Épée 1839 and MB&F.

Medusa has been developed with passion
and care by the Master Watchmakers
of L'Épée 1839 in Delémont, Switzerland.

CONTENTS

Important information	6
Care and maintenance	8
Medusa stance	10
How to display Medusa	12
The tentacles and dome in Murano glass	16
How to clean Murano glass	16
Reading the time	18
Winding and time-setting	20
Box content description	24

IMPORTANT INFORMATION

Please be very careful to never place Medusa horizontally, on its side – it should always remain in a vertical position. The pressure of the movement on the glass could break the Murano glass.

Medusa should never be in contact with any liquids – even in vaporized form. If this occurs, the clock should be serviced immediately.

A simple contact on certain components can generate delays in timekeeping, which can only be solved by servicing. Fingerprints will also damage the coating.

On the following picture, the only parts which can be cleaned or touched with precaution are those outside of the zone coloured in red; in case of intrusions, a service will be needed.

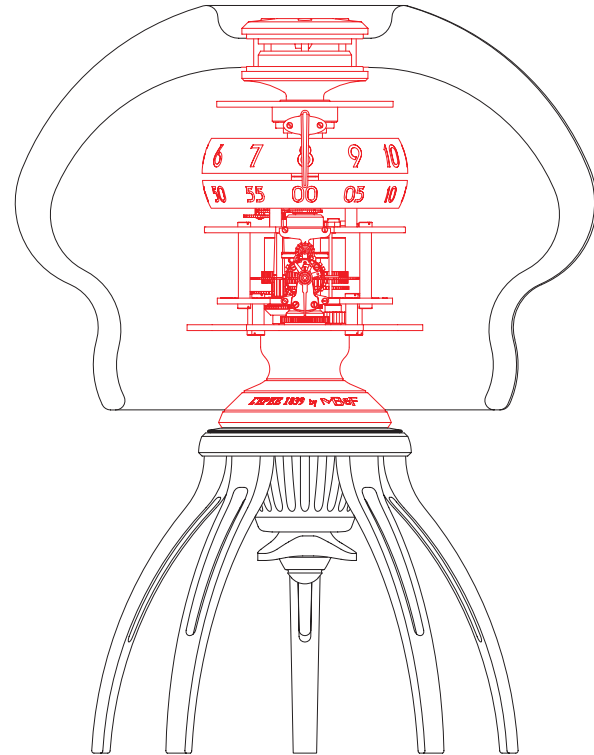

CARE AND MAINTENANCE

Use only a soft and dry cloth to clean the clock. Dust and particles contained in the cloth could scratch parts. Do not use any kind of cleaning products to clean the clock, the glass dome or the tentacles. It is recommended to keep the clock distant from any source of heat or vibrations. To preserve the longevity and functionality of Medusa, do not permanently expose the clock to direct sunlight or in a humid/dusty place.

Our clocks are developed to ensure optimal accuracy and reliability. It is well accepted for a fine mechanical clock to have a few seconds' variation per day and our clocks are set so as not to delay. However if you should notice a bigger variation, please contact an authorised dealer who will advise you, or a L'Epée 1839 technical support centre which will proceed with the necessary adjustment.

As for all Horological pieces of art, it is recommended to periodically service your clock. A mechanical masterpiece requires fine oils for the lubrication of the movement. These oils deteriorate over the years. We therefore advise having the movement serviced every 3 to 5 years. Be aware that the optimal period between servicing times can vary depending on the surrounding environmental conditions.

It is recommended to hold Medusa by the glass dome or underneath (see the blue parts highlighted on the diagram).

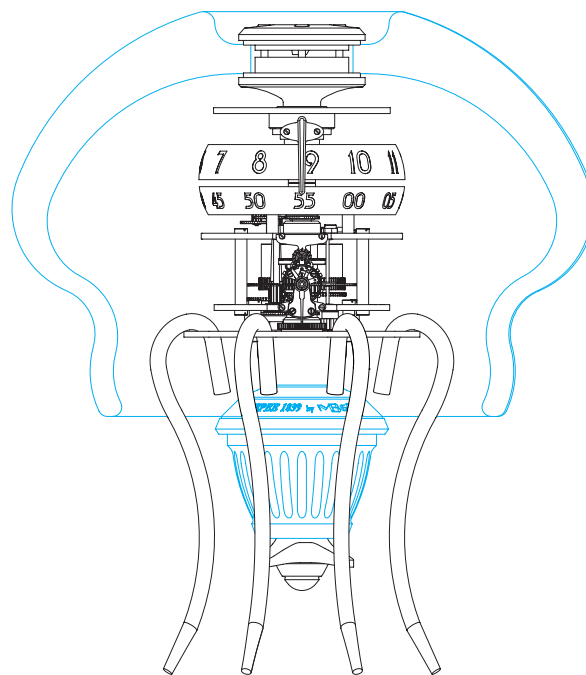

MEDUSA STANCE

Medusa – hung from the ceiling

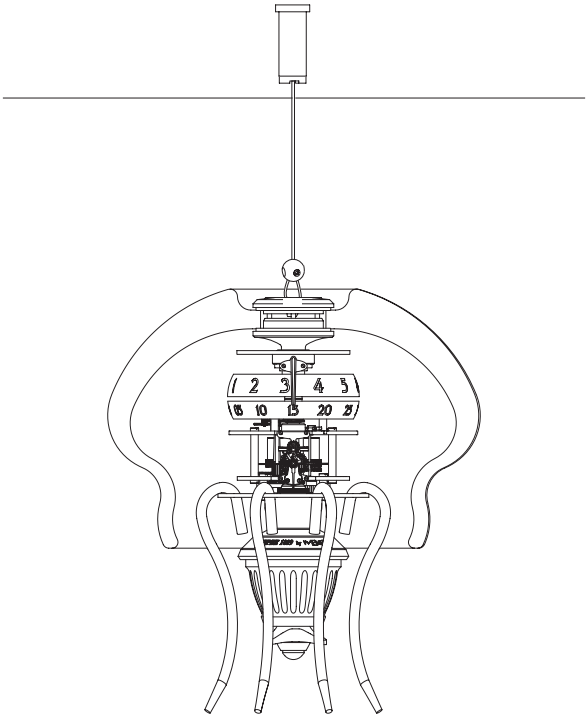

Medusa – standing on a table

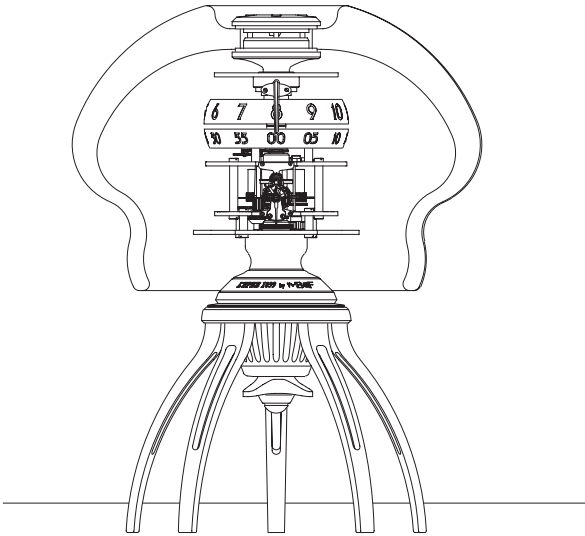

HOW TO DISPLAY MEDUSA

HUNG FROM THE CEILING:

Hang Medusa from the ceiling, thanks to the provided system.

SEVERAL PIECES COMPOSE THE SYSTEM:

- 1 - The fastening hook on Medusa
- 2 - The cable
- 3 - The cable retainer screw
- 4 - The mounting module for the ceiling (2 parts)
- 5 - Not provided : the screw adapted to the ceiling

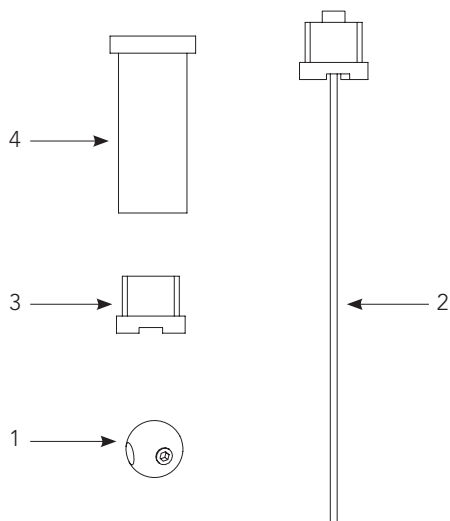

HOW TO HANG:

- A - Adjust the cable length
- B - Use the appropriate tools to fix the first part of the mounting module on the ceiling
- C - Screw the second part of the mounting module with the cable in the first part
- D - Make a loop at the extremity of the cable and secure by tightening the cable retainer screw
- E - Place the loop in Medusa's fastening hook located at the top of the clock

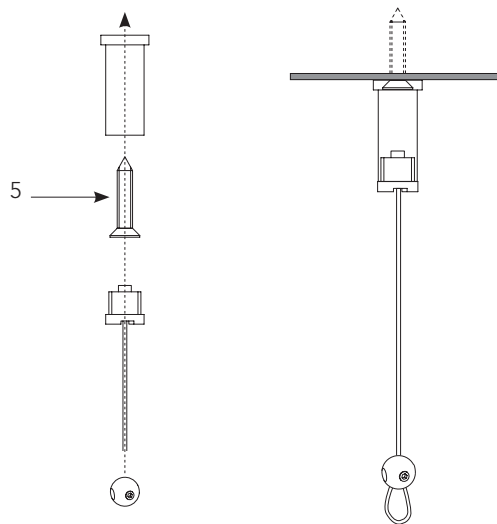

HOW TO DISPLAY MEDUSA

STANDING ON A TABLE:

Remove the tentacles before gently placing Medusa on its stand on a firm and stable surface.
To avoid any damage, we do not recommend placing the tentacles when Medusa is on its standing base.

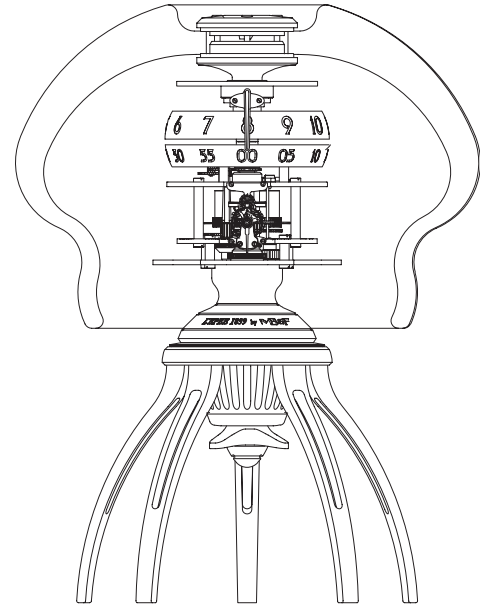
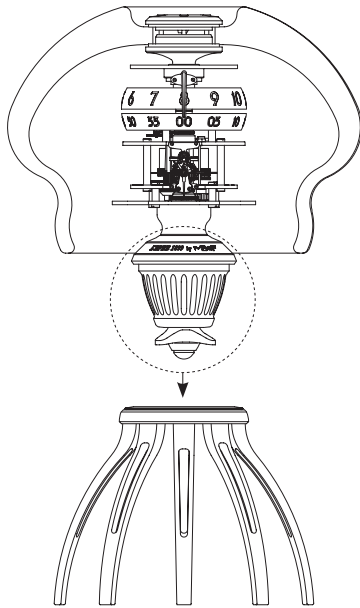

THE TENTACLES AND DOME IN MURANO GLASS

The tentacles are very fragile; we therefore strongly recommend removing the tentacles before any manipulations. The tentacles are not fixed to the clock's dome but to the movement, close to the escapement system; care is needed to not damage the escapement (red parts) when placing and removing the tentacles.

To avoid any damage, we recommend placing and removing the tentacles when Medusa is hung from the ceiling and not when Medusa is standing on its base.

HOW TO CLEAN MURANO GLASS:

You can clean the Murano glass with standard glass cleaner but be careful not to spray the movement; otherwise the clock should be serviced immediately.

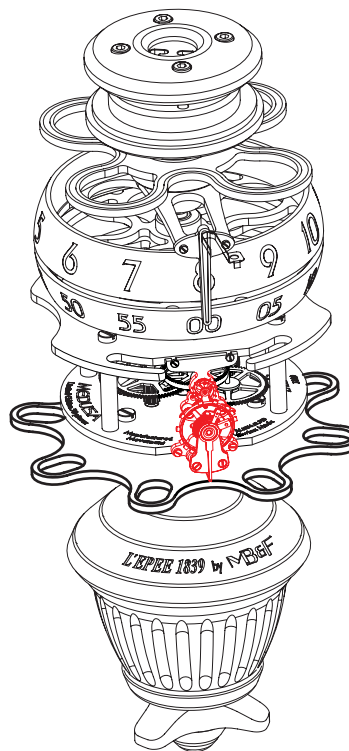

READING THE TIME

Time: 8H55

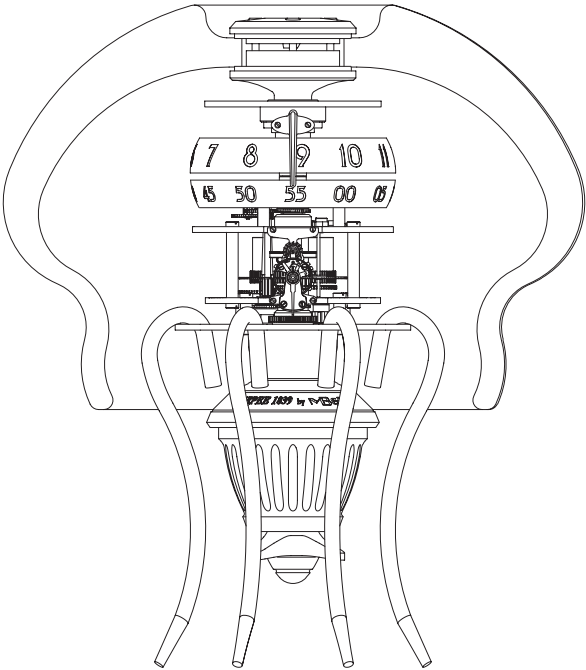

Time: 3H15

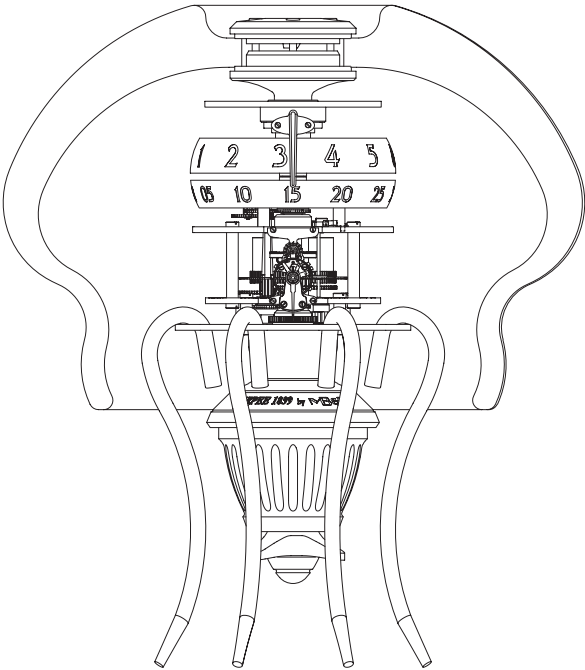

WINDING AND TIME-SETTING

To wind the movement or set the time you can either place Medusa on its stand, or remove the tentacles when it is suspended; then hold the movement by the highlighted blue part on the diagram below. If nonetheless you decide to leave the tentacles in place when manipulating the clock, be careful not to push the tentacles outside of their position as they are only hung and not fixed.

Wind the movement by turning the propeller located at the bottom on the movement (red part on the diagram) with anti-clockwise rotations. The movement should be fully wound once a week (the clock's power reserve is 7 days). Be sure to wind the spring completely: you will notice that the necessary force increases significantly, but do not wind further as this is the sign that the movement is fully wound. Excessive winding beyond this point will damage the spring, requiring servicing.

To set the time, turn the same propeller but rotate clockwise.

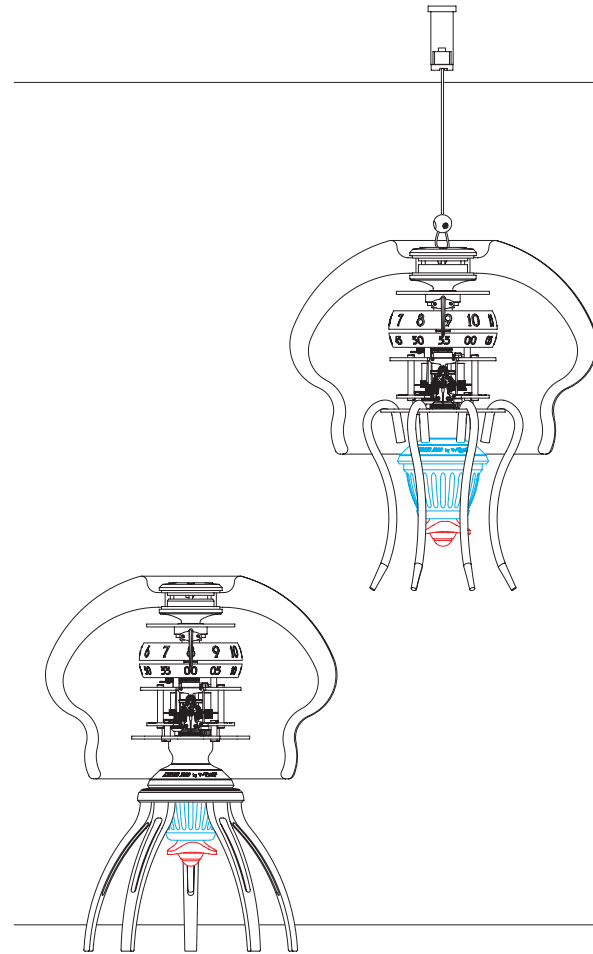

SET THE TIME

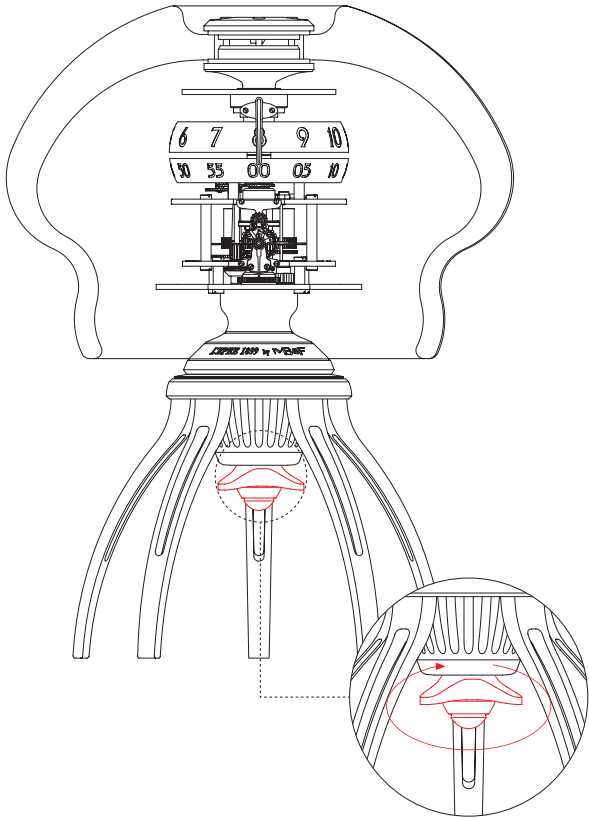

WIND THE MOVEMENT

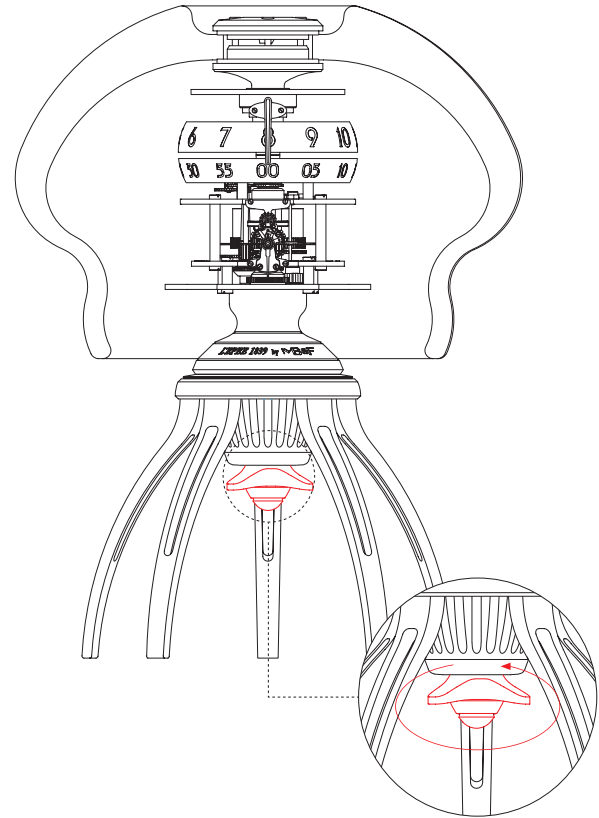

BOX CONTENTS DESCRIPTION

FIRST BOX :

- A : Murano glass dome
- B : Movement
- C : Murano glass tentacles

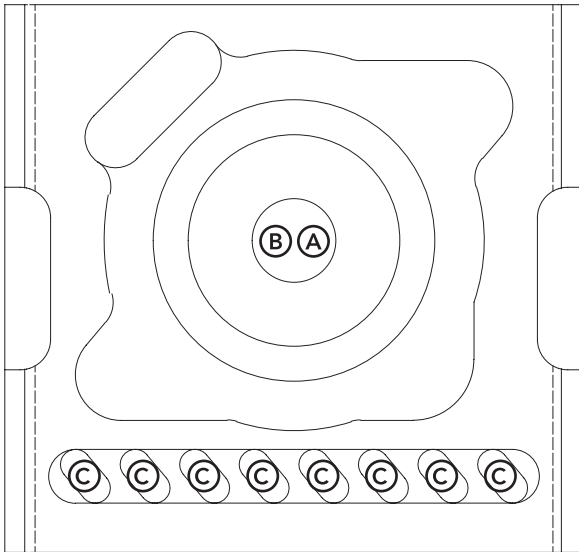

SECOND BOX:

- D: Standing base

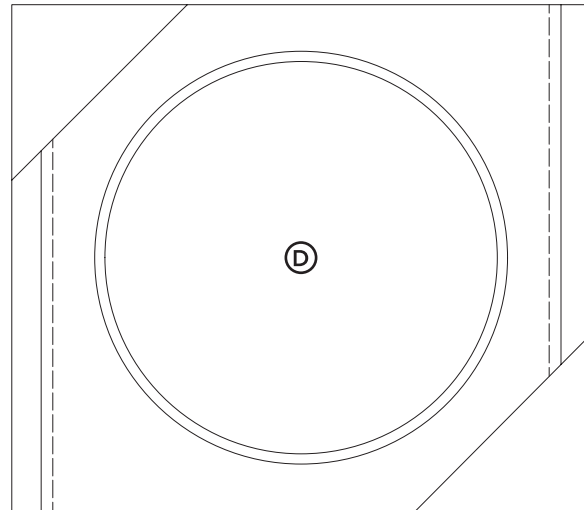

L'Épée 1839
Manufacture Horlogère

Rue St-Maurice 1 - P.O. Box 973
2800 Delémont
Switzerland
Tel. +41 (0)32 421 94 00

After Sales Services:
sav@swiza.ch
Tel. +41 (0)32 421 94 05

www.lepee1839.com